

# MODEL F/S-3V-II & F/S-3V-3-II

## Combination Fire/Smoke Damper

UL 555 and ULC S112 Listed for 1-1/2 and 3 Hour Rated  
UL 555S and ULC S112.1 Listed Class II Leakage

UL File No.  
R25410

### Standard Construction:

**Frame:** Roll formed galvanized steel hat-section with staked corners and integral bracing.

**Blades:** 16 ga roll formed galvanized steel.  
Minimum width: 4.25" (108 mm)  
Maximum width: 7.25" (184 mm)

**Bearings:** Bronze Oilite, press-fit into frame.

**Axles:** Square, plated steel.

**Seals:** Pressure sensitive 450°F silicone blade edge seals and flexible metal jamb seals.

**Linkage:** Concealed in frame. Linkage bars are .125" (3.2 mm) thick plated steel.

**Controlled Closure Device:** (Heat Activated)

EFL - 165°F Standard, 212°F, 250°F, 350°F available

PFL - 165°F Standard, 212°F available

\*Due to space limitations, Dampers below 12" tall with no sleeve and actuators in the airstream will be equipped with a spring/fuselink assembly in lieu of the EFL temperature response device.

**Finish:** Mill galvanized.

**Actuator:** UL Approved, See Actuator Page, depends on damper size and temperature rating, External or Internal Mounted.

**Maximum Velocity:** 2000 fpm (10.2 m/s) on all sizes.

**Maximum Pressure:** 4" w.g. (1kPa)

### Sizes:

Minimum Size: 6"w x 6"h (203mm x 152mm)(Ext. Actuator)

Minimum Size: 12"w x 10"h (254mm x 356mm)(Int. Actuator)

Max. - Single Section: 36"w x 48"h (914mm x 1219mm)

Max. - 1-1/2 hr. Vertical: 108"w x 96"h (2743mm x 2438mm)

Max. - 1-1/2 hr. Horizontal: 144"w x 96"h (3657mm x 2438mm)\*

Max. - 3 hr. Vertical: 72"w x 48"h (1828mm x 1219mm)

Max. - 3 hr. Horizontal: 72"w x 48"h (1828mm x 1219mm)

\*(May Ship in Multiple Sections for Field Assembly)

### Features:

- The F/S-3V-II or F/S-3V-3-II series Combination Fire/Smoke Dampers have been designed and tested to exceed all UL, ULC, and NFPA requirements for fire dampers as well as smoke dampers.
- F/S-3V-II is UL 555 and ULC S112 listed and labeled as an 1-1/2 hour rated fire damper.
- F/S-3V-3-II is UL 555 and ULC S112 listed and labeled as a 3 hour rated fire damper.
- UL and ULC listed for both vertical and horizontal mountings.
- UL 555S /ULC S112.1 listed and labeled as a Class II rated Smoke Damper with airflow in both directions. Class II provides for a max. leakage of 20 cfm/sq ft at 4.0" wg static pressure.

### Notes:

- Non-sleeved dampers with side plates are furnished approximately 1/4" (6.4 mm) smaller than given duct dimensions. Sleeved dampers are furnished approximately same size as given duct dimension unless otherwise noted.
- Not recommended with blades running vertical.
- It is recommended the damper must be inspected and cycled at intervals not greater than every twelve months or in accordance with NFPA 80, 90A, 92A, local codes and the actuator manufacturer.

### Suggested Specifications:

Combination Fire/Smoke Dampers shall be model: F/S-3V-II or F/S-3V-3-II, by United Enertech. Fire/Smoke Dampers shall bear the Underwriters Laboratories labels for both Fire Dampers and Smoke Dampers. UL 555S / ULC S112.1 ratings shall be Class I with leakage not to exceed 20 cfm per sq ft. at 4.0" static pressure for any size. Linkage shall be of the concealed type for maximum free area.

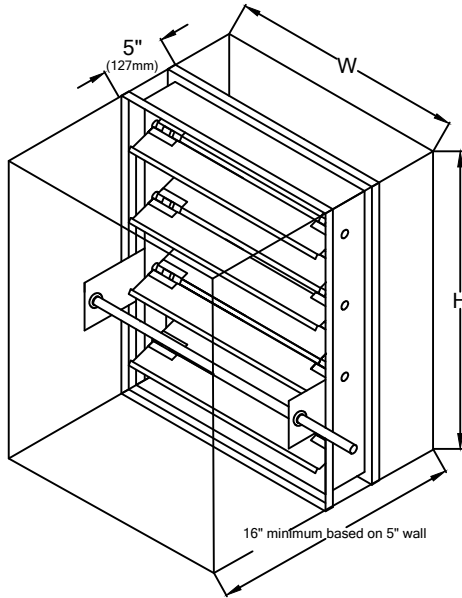

U.L. 555S Classified at 250°F or 350°F depending upon Actuator/Operator  
\*See Actuator/Operator Schedule

Note: Due to continuing research, UE reserves the right to change specifications without notice.

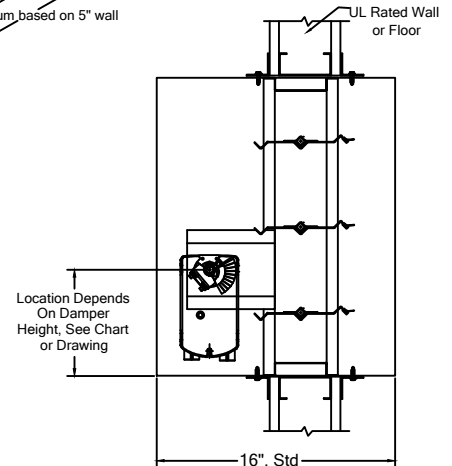

### Options:

- Factory sleeves \_\_\_\_\_ ga. (20 ga minimum).  
Length \_\_\_\_\_ inches (min. 16").  
(16" x 20 ga side plate provided if no sleeve is indicated, Act. External)
- Retaining Angles
  - One Side
  - Both Sides
- Transitions
  - Round
  - Oval
- Actuator
  - Electric, \_\_\_\_\_ vac (Voltage)
  - Pneumatic, 25 psi
- Grille Mtg. - 3/4" Mounted Face Flange
  - Shipped loose, 1" (if external actuator)
- Mounting Orientation
  - Vertical
  - Horizontal
- Smoke Detector
  - Ionization
  - Photoelectric
- DTO/RE w/ M/S Package
- M/S Blade Mounted end switch
- Built in Actuator position End Switch
- Remote Control Boxes  
 RCB-1    RCB-2    RCB-3    RCB-4

Job Name:	<input type="checkbox"/> <b>MODEL F/S-3V-II (1-1/2 hour)</b>		
Location:	<input type="checkbox"/> <b>MODEL F/S-3V-3-II (3 hour)</b>		
Architect:	DRAWN BY:	DATE:	REV. DATE:
Engineer:	GAB	11-12-07	2-11-20
Contractor:	REV. NO.	APPROVED BY:	DWG. NO.:
	7	CLJ	<b>P-41</b>

**Performance Data**

Pressure drop testing was done by an independent laboratory to the AMCA Standard 500-D, Fig. 5.3 ductwork upstream and downstream.

**Damper Size 36 x 36**

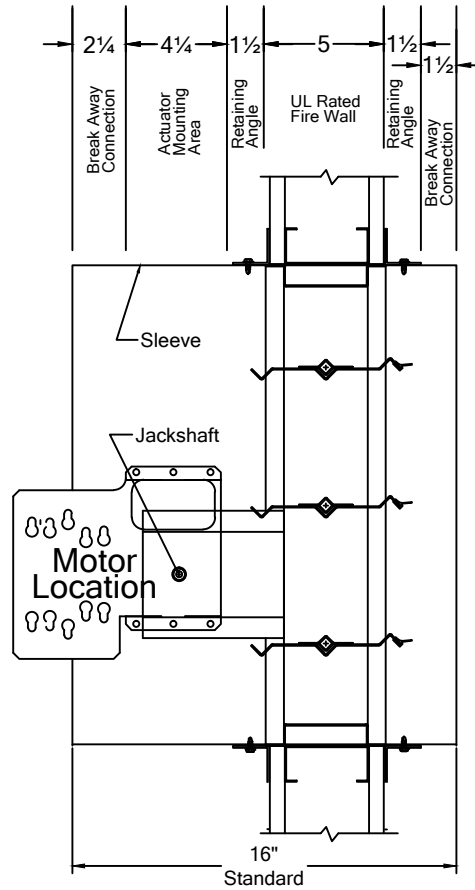
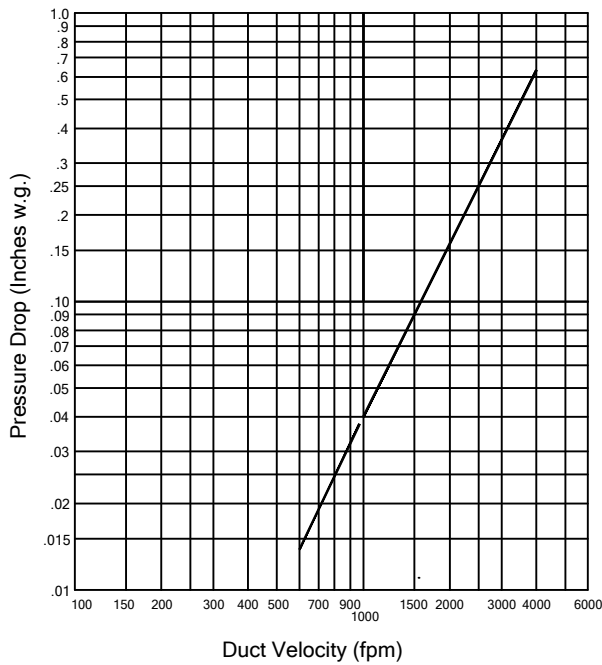

When the actuator is externally mounted and the wall thickness exceeds 5 inches, add 1 inch for each additional inch of wall thickness increased, to ensure sleeve extends through the penetration. As standard the actuator is externally installed on the lower right hand half of the damper when viewed from the jackshaft side. The damper may be installed or rotated 180° so the actuator will be located on the upper left. The top of the damper is either side of the frame as long as the blades are running horizontal. When ordering internally mounted actuators, be aware there is a min. height requirement (in some cases the sleeve can be increased to allow for internal mounting). The entire damper frame does not have to be installed in the plane of the wall or floor. The rule of thumb is "with the damper in the closed position, the blade plane should be within the plane of the UL rated wall/floor".

**Damper Size 24 x 24**

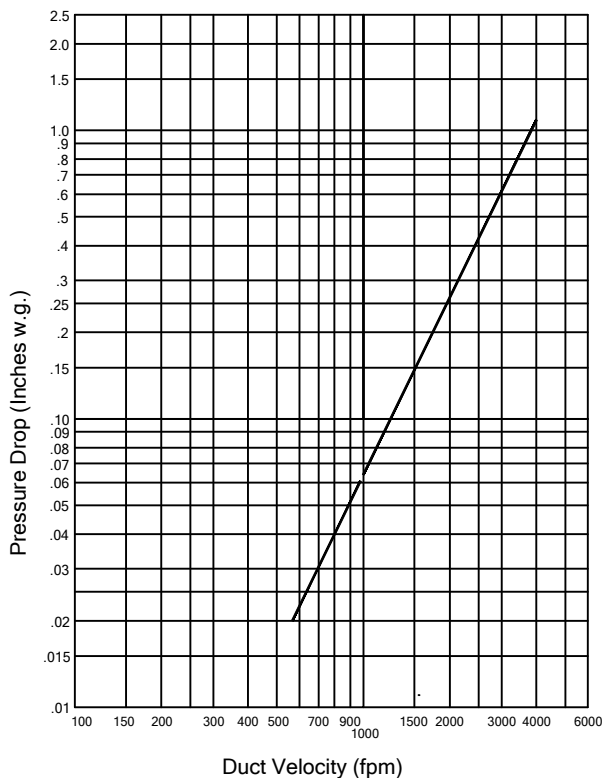

**Damper Size 12 x 12**

